



A320 SR SAFETY INFORMATION

Federal regulations require compliance with crew instructions, lighted passenger information signs and posted placards at all times.

If you are seated at an exit and are unable to understand the information on this card, please contact a flight attendant.

Exit（非常口）の列にお座りなっていて、このカードの内容が理解できないと思われる場合は、搭乗員までお申し出ください。

Si vous êtes assis à côté d'une sortie de secours et vous ne comprenez pas les informations inscrites sur cette carte, n'hésitez pas à contacter un membre de l'équipage.

如果您坐在緊急出口的座位，但看不懂本卡片上的信息，請與空中服務員聯絡。

Wenn Sie an einem Notausgang sitzen und die gedruckten Anweisungen auf dieser Karte nicht verstehen, wenden Sie sich bitte an einen Flugbegleiter.

만약 귀하께서 출구에 앉으셨는데 이 카드의 내용을 이해하실 수 없으시다면 승무원에게 말씀해 주십시오.

Si usted está sentado(a) al lado de una puerta de salida y no entiende la información contenida en esta tarjeta, por favor dígaselo a un asistente de vuelo.

EXIT SEATS

Please notify a crewmember if you do not meet the following criteria or do not wish to assist in an emergency.

If you are seated in an exit seat, you may be asked to assist the crew in an emergency by performing the following functions.

- Follow oral instructions and hand signals given by the crew.
- Locate the emergency exit and determine if it is safe to open.
- Open the emergency exit as shown and secure the exit so it does not impede use of the exit.
- Activate the slide, if provided, pass quickly through the emergency exit, and assist others after exiting the aircraft.
- Select and follow a safe path away from the emergency exit.

No passenger may be seated in an exit seat if it is likely that he/she is unable to perform any of the functions listed above because:

- The person has insufficient mobility, strength, or dexterity in arms, hands or legs.
- The person cannot see or hear well enough to perform functions illustrated on this card.
- The person cannot verbally relate information to other passengers.
- The person is less than 15 years of age.
- The person has a condition or responsibilities such as caring for small children that might prevent him/her from performing listed functions illustrated on this card.
- The person has a condition that might cause him/her harm if he/she performs the functions illustrated on this card.

Final assembly of this aircraft was completed in France.



Flotation cushion
 浮き袋
 漂浮墊
 뜨는 방석
 Schwimmfähiges
 Sitzkissen
 Coussins flotteurs
 Asiento flotante



Life Vests
 救命胴衣
 救生衣
 구명조끼
 Schwimmwesten
 Gilets de sauvetage
 Chalecos salvavidas

Available on select aircraft.

特定の航空機ご利用できます。

只有部份特定航機可提供。

특정비행기에 비치됨.

Steht in bestimmten Flugzeugen zur Verfügung.

Disponible sur des avions choisis.

Disponible únicamente en aviones elegidos.

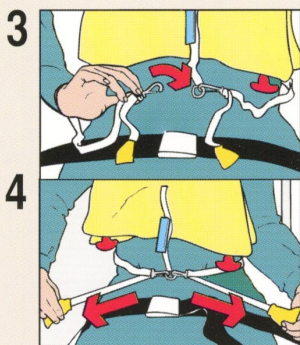
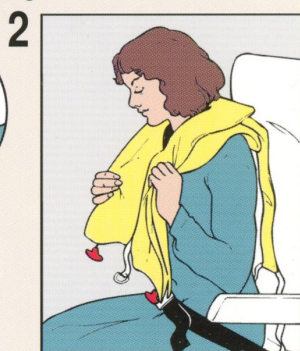
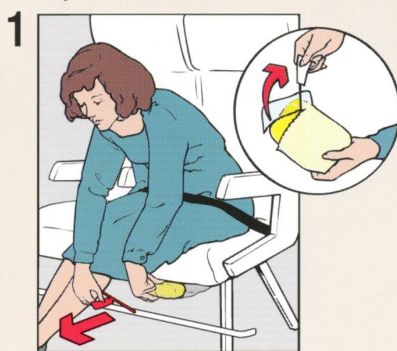

4

5

Exit
 非常口
 通道
 출구
 Ausgang
 Sortie
 Salida

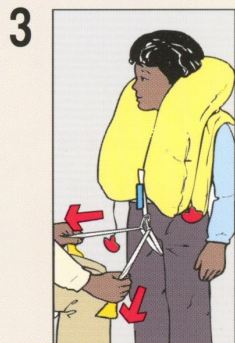



While seated
お座席では
在座時
착석해 있는 동안
Während Sie sitzen
Lorsque vous êtes
assis
Mientras está
sentado



No smoking at any time on board this airplane.
この航空機内は常時禁煙です。
任何時間在本機内請勿吸烟
이 비행기에 타신 후에는 항상 금연으로 되어있습니다.
Rauchen an Bord dieses Flugzeugs ist keinerlei
gestattet.
Interdiction permanente de fumer à bord de cet avion.
No fumar en ningún momento a bordo de este avión.



Oxygen
酸素マスク
氧氣
산소 마스크
Sauerstoff
Oxygène
Oxígeno

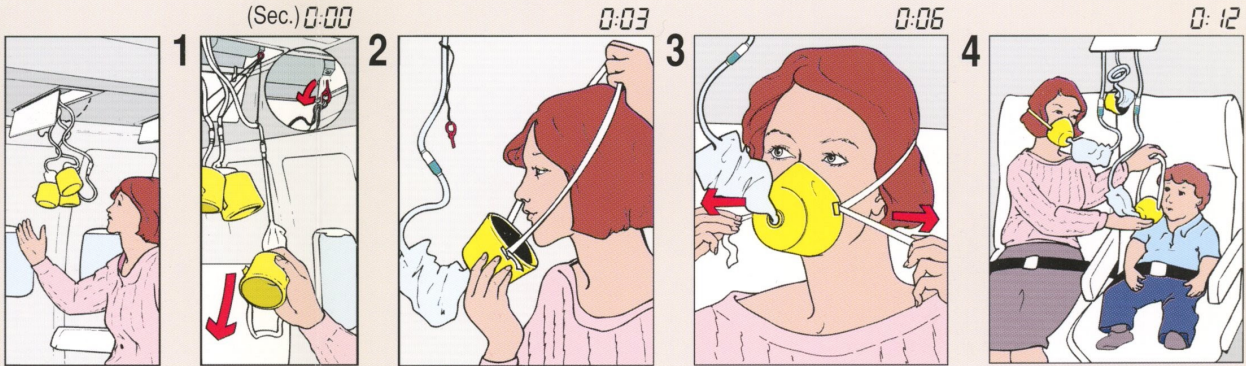

A

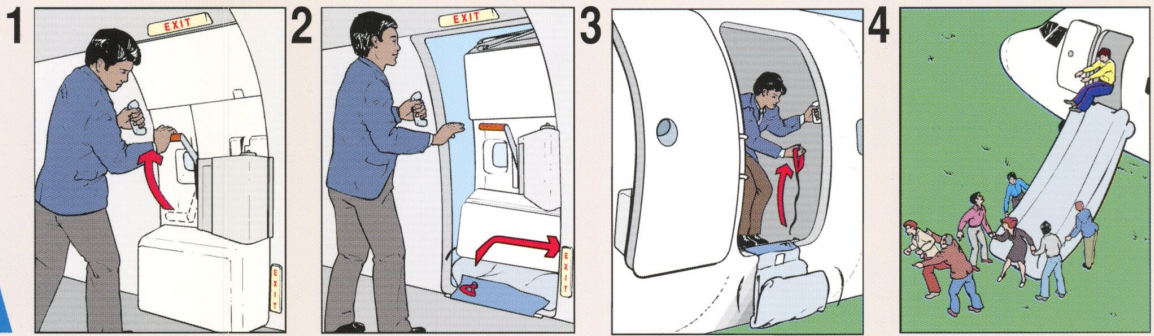

B





While seated
お座席では
在座時
착석해 있는 동안
Während Sie sitzen
Lorsque vous êtes assis
Mientras está sentado

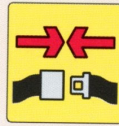

Oxygen
酸素マスク
氧氣
산소 마스크
Sauerstoff
Oxygène
Oxígeno

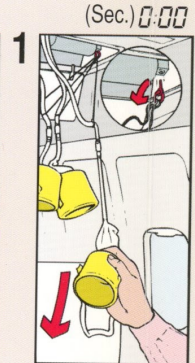

(Sec.) 0:00

EXIT Smoke/Fire Debris Water

UNSAFE TO OPEN EXITS

開
打
開
여
감
시
오
O
u
v
r
i
r
A
b
r
i
r

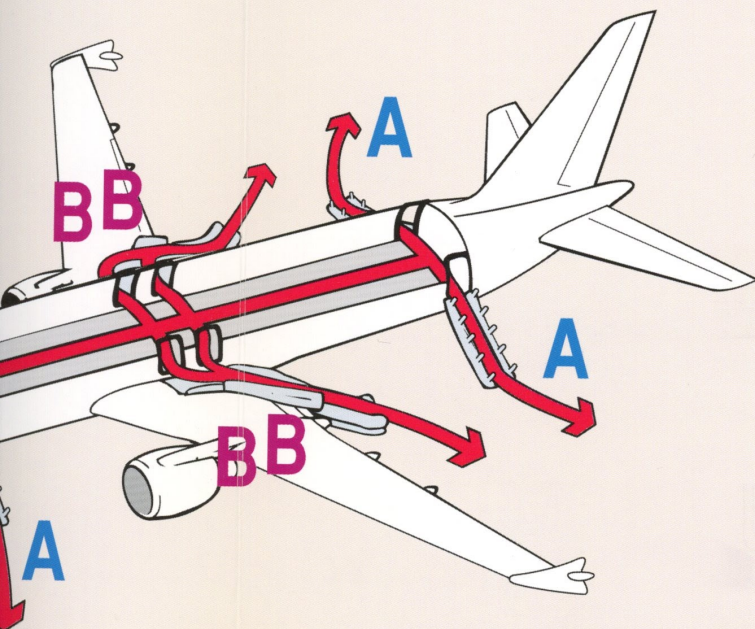

A



B



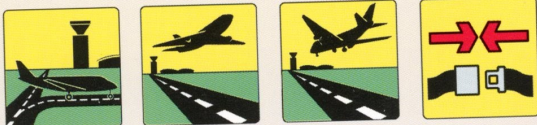

Taxi, Take-off, & Landing

走行、離陸、着陸
滑行、起飛和降落
주행, 이륙 및 착륙

Rollen, Abflug und Landung
Déplacement au sol, décollage
et atterrissage
Durante el rodaje, el despegue,
y el aterrizaje

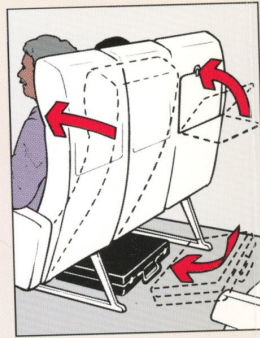

Do not use...

機内では以下のものは使用しないでください。

請勿使用...

이것들을 사용하지 마십시오.

Benutzen Sie nicht...

Ne pas utiliser...

No use...

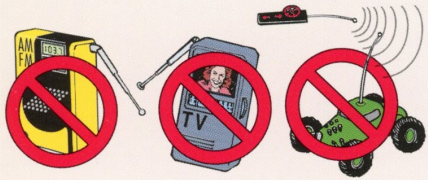

Brace positions

安全姿勢

安全姿勢

지지 자세

Schutzhaltungen

Positions de sécurité

Posiciones de seguridad



Emergency exits

非常口

緊急出口

비상구

Notausgänge

Sorties de secours

Salidas de emergencia



Smoke/Fire



Debris



Water

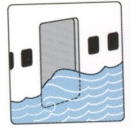

UNSAFE TO OPEN EXITS

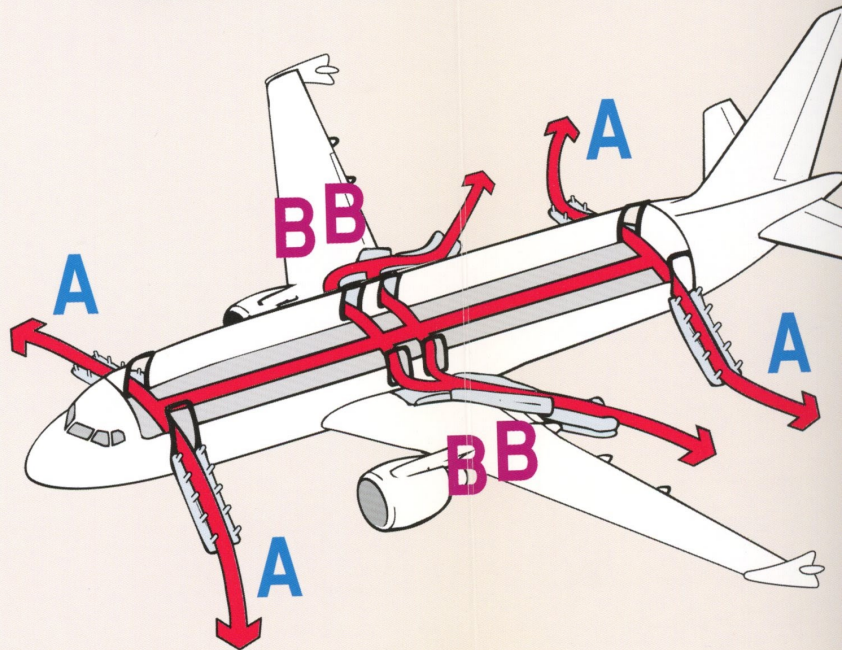



Life Rafts
 救命ボート
 救生筏
 구명보트
Schlauchboote
Canot pneumatique
Balsas salvavidas

